

Instructions for use

UMTS modem

alpha UMTS WTM PC

alpha UMTS WTM 2 PC

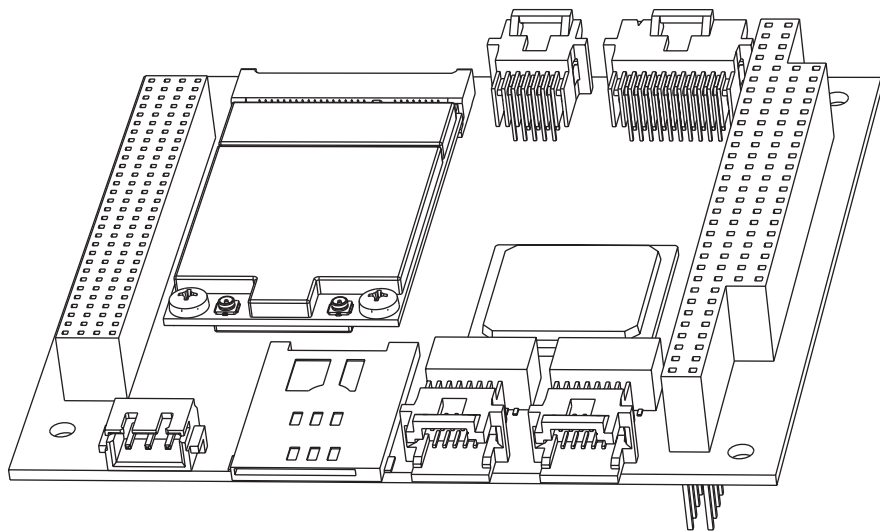

Safety precautions

The UMTS modem **alpha UMTS WTM PC / alpha UMTS WTM 2 PC** complies with the European norm EN60950 – safety of information technology equipment.

- **Do not use or install your unit in rooms with explosive material!**
- **Do not touch the device terminals with metallic or sharp objects!**
- **The connection cables of the unit may only be plugged into the designated sockets!**
- **Never install the unit during a thunderstorm!**
- **Protect the unit from heat sources and direct sunlight!**
- **Protect the unit from dust, moisture, aggressive liquids and steam!**
- **The unit may only be connected to approved accessories!**
- **The unit should only be passed on to a third party including complete operating instructions!**
- **When the alpha UMTS WTM PC / alpha UMTS WTM 2 PC has reached the end of its service life, it has to be disposed of in an environmentally friendly manner!**

alpha UMTS WTM PC / alpha UMTS WTM 2 PC

The **alpha UMTS WTM PC / alpha UMTS WTM 2 PC** is an UMTS modem with integrated router in PC/104 format.

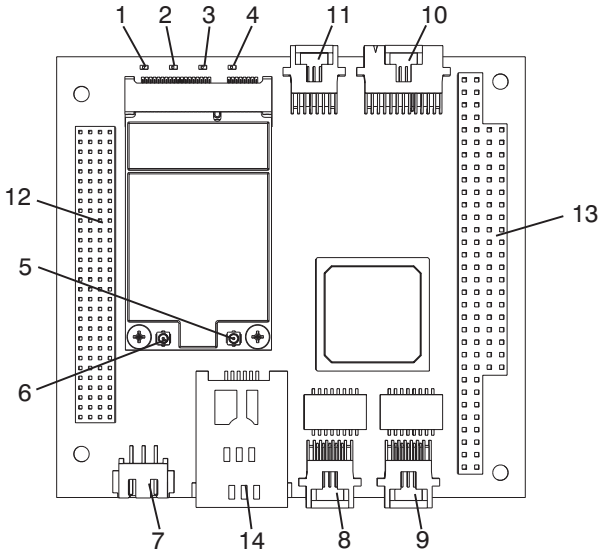

LEDs:

- | | | |
|---|--------------|---|
| 1 | Power | LED for the operating condition of the modem |
| 2 | WWAN | LED for the UMTS connection (Wireless WAN) |
| 3 | LAN B | LED for the condition of the LAN connection B |
| 4 | LAN A | LED for the condition of the LAN connection A |

Connections:

- | | | |
|----|-----------------|---|
| 5 | Antenna | Connection for UMTS antenna |
| 6 | Antenna | Connection for passive GPS antenna (only alpha UMTS WTM 2 PC) |
| 7 | Power | Connection for external power supply (alternative to PC/104) |
| 8 | LAN B | Standard Ethernet connection for PC |
| 9 | LAN A | Standard Ethernet connection for network devices |
| 10 | LED | Connector for connection external LED |
| 11 | RS232 | RS232 connecting socket |
| 12 | PCI | PCI connector according to PC/104-Plus specification |
| 13 | ISA | ISA connector according to PC/104 specification |
| 14 | SIM-Card | SIM-Card Reader |

Checking the content of the package

Delivery scope:

- UMTS modem **alpha UMTS WTM PC** or **alpha UMTS WTM 2 PC**
- 2 LAN adapter cables (RJ45 socket on 10-pole connector)
- Instructions for use

Connecting the UMTS modem and entering the SIM card

In the following picture you can see how you have to cable the **alpha UMTS WTM PC / alpha UMTS WTM 2 PC**:

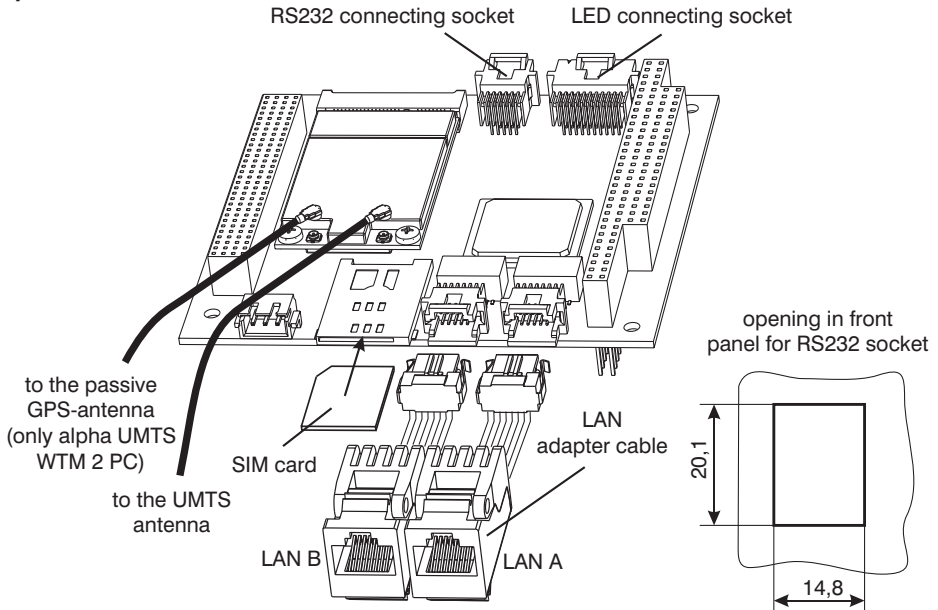

1. Enter the SIM card into the SIM card holder.
2. Attach the modem to a PC/104 slot. The voltage supply is realized over the PC/104 connector.
3. The provided LAN adapter cables are attached to the 10-pole LAN sockets of the modem. The RJ45 sockets can be snapped into the appropriate openings of a front panel.
4. The antenna line (provided by the user) is attached to the UMTS antenna socket of the UMTS module. A passive GPS antenna can be attached to the GPS antenna socket (only at **alpha UMTS WTM 2 PC**).
5. By means of usual Ethernet connection cables, the LAN sockets of the LAN adapter can be connected with a PC or other network devices.

Please note:

The non-compliance of the operating voltage at the PC/104 connectors can lead to the destruction of the modem.

Only exchange the SIM card when the modem is disconnected from the power supply.

Assignment of the connecting sockets

- 1. Antenna socket for UMTS antenna and passive GPS antenna**
(only at **alpha UMTS WTM 2 PC**) on the UMTS module
(appropriate connector U.FL plug e. g. Hirose U.FL-LP-066)

- 2. Connecting socket for internal voltage supply 3-pole**

PIN	Assigned with
1	0 Volt (GND)
2	+ 3.3 Volt
3	not used

JST S3B-XH-SM3-TB (LF)

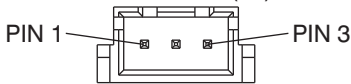

Please note:

The 3-pole connecting socket for internal voltage supply may only be used as alternative to the voltage supply over the PC/104 connectors and not at the same time.

- 3. LAN connecting socket 10-pole for Ethernet connection with computer or network devices with 10BaseT or 100BaseT**

LAN connecting socket 10-pole

PIN	LAN A	LAN B
1	TX+	RX+
2	RX +	TX +
6	TX -	RX -
8	RX -	TX -
3, 4, 5, 7, 9, 10	not used	not used

RJ45 socket at LAN adapter cable

PIN	LAN A	LAN B
1	TX+	RX+
2	TX -	RX -
3	RX +	TX +
4,5	not used	not used
6	RX -	TX -
7, 8	not used	not used

Tyco/AMP 5-104069-4

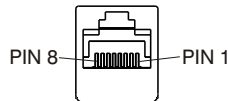
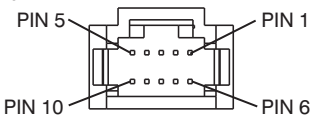

Connection

4. LED connecting socket 20-pole for external signalling (appropriate connector: AMP order no.: 111196-4)

Contact PIN	Assigned with	Contact PIN	Assigned with
1	1E Link +	11	Bridge +
2	1E Link -	12	Bridge -
3	1E Act +	13	res.
4	1E Act -	14	res.
5	2E Link +	15	res.
6	2E Link -	16	res.
7	2E Act +	17	res.
8	2E Act -	18	res.
9	WWAN +	19	res.
10	WWAN -	20	res.

Tyco/AMP 5-104069-1

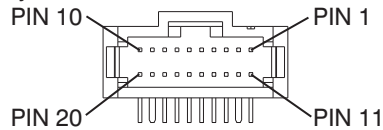

5. RS232 connecting socket 10-pole (appropriate connector: AMP order no.: 111196-1)

Contact PIN	Assigned with	Contact PIN	Assigned with
1	res.	6	res.
2	res.	7	0 Volt (GND)
3	not used	8	0 Volt (GND)
4	RTS 8	9	RxD 3
5	CTS 7	10	TxD 2

Tyco/AMP 5-104069-4

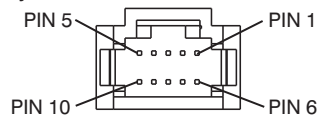

Please note:

Nothing may be connected to the contact PINs that are marked with res. (reserved)!

Putting into operation and indications

Two operating modes are supported:

1. Router: The unit functions as broadband router
2. PPPoE: The unit functions as modem with PPPoE interface

Required software drivers:

In the operating mode router, only the current Ethernet and network drivers (TCP/IP) are required on the connected PC.

In the operating mode PPPoE, a PPPoE driver has to be installed and activated on the PC to which the **alpha UMTS WTM PC / alpha UMTS WTM 2 PC** is connected.

Note:

The PPPoE driver for current windows versions can e. g. be downloaded on the website www.raspppoe.com.

After inserting the SIM card and the correct cabling of the **alpha UMTS WTM PC / alpha UMTS WTM 2 PC**, the following status indications should be visible at the front of the modem (see fig. page 3):

Status indication	Meaning
Power	Supply voltage available
WWAN	Continuous light or slow blinking
LAN A	LAN connection to the network device (switch or hub) or PC
LAN B	LAN connection to the PC

For the configuration of the **alpha UMTS WTM PC / alpha UMTS WTM 2 PC**, a **web interface is available which can be operated from a PC that is connected by means of a LAN connection cable.**

The IP address of the **alpha UMTS WTM PC / alpha UMTS WTM 2 PC** that is set by default is 192.168.192.168 with the network mask 255.255.255.0. The PC that is used for the configuration has to be configured that way that it is able to communicate with this default setting.

For safety reasons, you should use HTTPS for the communication with the web interface since the data is transmitted encoded this way.

Please note:

Keep in mind that the configuration of the LAN interfaces is done that way that you can always access the **alpha UMTS WTM PC / alpha UMTS WTM 2 PC** over these interfaces.

Configuration over the web interface

The web interface is for the configuration, the control and the update of the **alpha UMTS WTM PC / alpha UMTS WTM 2 PC**.

For accessing the web interface, all current browsers in their latest versions are suitable. The web interface is accessible in the standard configuration over HTTP or HTTPS on the IP address 192.168.192.168 (<http://192.168.192.168> or <https://192.168.192.168>).

Configuration

The current configuration (set in the web interface) can either be accepted directly or be saved on the **alpha UMTS WTM PC / alpha UMTS WTM 2 PC** or in a file.

The configuration can be reset to different states. Apart from the reset to the configuration saved last, all other activities lead to the overwriting of the saved configuration.

The configuration can be loaded from the **alpha UMTS WTM PC / alpha UMTS WTM 2 PC** or over a file upload.

For activating a configuration, this configuration has to be saved and the unit has to be rebooted.

Network configuration

Please note:

Network settings may only be carried out with the appropriate knowledge of the network technology since, in the worst case, the **alpha UMTS WTM PC / alpha UMTS WTM 2 PC** will not be accessible over the network anymore.

Before activating a configuration, write down all new settings as well as the old settings in order to be able to go back to these, if necessary.

The reset to factory default does not function in every case.

WAN settings

The **alpha UMTS WTM PC / alpha UMTS WTM 2 PC** supports 2 operating modes:

1. PPPoE Relay (UMTS modem) or
2. NAT Gateway (UMTS router).

As PPPoE Relay, it can be connected to a router or a PC and transmits the PPP dial-up connection over PPPoE. As NAT Gateway, it can provide Internet over Ethernet in a local network.

When changing the operating mode, the LAN settings may also change!

Please check the LAN settings before an activation!

1. UMTS modem

APN (access point name) and in some cases the user name with password for the PDP context are required. Additionally, a PIN for the SIM card has to be stored.

For updates via the Internet and for remote access to the web interface, gateway and DNS of the connected local network have to be given since the modem transfers the dial-up connection and therewith has no own WAN IP address.

Configuration over the web interface

2. UMTS router

APN, the access data for the PDP context and the PIN are also required for this operating mode.

For the PPP access data, the same values as for the PDP context are used.

Usually, the provider transfers IP address, gateway and DNS.

For the dial-in on request, it is necessary to give any IP address.

It is recommended to firmly enter the DNS servers, for which you also have to ask the provider, since this is often not transmitted.

For the maintaining of the connection, it can be necessary to generate a continuous traffic. This can be achieved by means of the ping targets that are polled alternating at intervals of 5 seconds.

LAN settings

Depending on the WAN operating mode, there are several configuration possibilities for the LAN settings.

LAN A or LAN B only switch on the respective interface.

At LAN A+B, both interfaces can be configured independently of each other. In switch mode, the two connections LAN A and B constitute a bridge. Logically, this is then only one interface.

Every interface can be operated in 3 (as modem 2) different modi:

1. Static

In this configuration, IP address and network mask have to be given.

These settings have to be written down since the web interface can only be accessed by means of these settings.

2. Dynamic (DHCP client)

As DHCP client, the **alpha UMTS WTM EG / alpha UMTS WTM 2 EG** asks for an IP address in the local network and configures itself accordingly.

You determine the assigned IP address either at your DHCP server or by means of traces of the Ethernet connection.

3. DHCP Server (only as router)

In this configuration, the **alpha UMTS WTM EG / alpha UMTS WTM 2 EG** can assign IP addresses per DHCP itself. Next to the configuration of the IP address as well as the network mask, a range from which IP addresses can be assigned has to be given.

Firewall (only as router)

The **alpha UMTS WTM EG / alpha UMTS WTM 2 EG** has a simple firewall to allow incoming connections (from the WAN) and to block outgoing connections. Furthermore, services can be forwarded to members of the LAN by means of port forwarding. Only a limited number of entries can be made. For the remote configuration, TCP-Port 80(HTTP), 443(HTTPS), 23(TELNET) and 22(SSh) have to be activated. Port forwarding of these interfaces should also be avoided. For the port forwarding and the remote access you have to keep in mind that many providers do not assign public IP addresses.

Configuration over the web interface

OpenVPN Client (only as router)

The **alpha UMTS WTM PC / alpha UMTS WTM 2 PC** can take part in a virtual private network as OpenVPN Client. Next to the encoding of the data, this also provides the opportunity for remote maintenance of the modem or units behind the modem, which is not possible in most UMTS networks because of the missing public IP address.

The log recordings are only intended to be used for debugging. After successful erection of the tunnel, it should be deactivated again.

There are two operating modes:

At an IP tunnel (tun), a point-to-point connection between server and **alpha UMTS WTM PC / alpha UMTS WTM 2 PC** is established. Units in the LAN then are accessible via port transmission or appropriate routes in the server.

At a bridge (tap), the LAN protocol is transferred. The units then are accessible directly, but there is much more traffic. DHCP is also transferred and can lead to big problems in the VPN.

For the authentication, either a static key or a PKCS12 certificate can be used.

System settings

General settings are made here.

In case it is used as DNS server, the **alpha UMTS WTM PC / alpha UMTS WTM 2 PC** can directly be accessed over the host name. The domain name can be added to the host names in case of name resolution.

The password for the web interface can also be changed. Standard is an empty password. Please keep in mind that HTTP transmits passwords uncoded (also at the login). In case you are in an insecure network, use HTTPS.

Normally, every **alpha UMTS WTM PC / alpha UMTS WTM 2 PC** generates an own HTTPS certificate with corresponding key. But you can also install an own certificate. This certificate can for example be generated by means of OpenSSL with the following command line:

```
openssl req -new -newkey rsa:1024 -keyout <filename> -nodes -x509 -out <filename>
```

For further possibilities, please have a look at the OpenSSL documentation under <http://www.openssl.org>.

For some services, a date that is set correctly is required. For this, several NTP time servers can be given next to the time zone.

GPS functions

GPS functionality is made available by a software update, it is described in the latest user manual **alpha UMTS WTM PC / alpha UMTS WTM 2 PC** in the Internet under www.fmncom.com.

Update

Updates are provided by the manufacturer FMN communications GmbH and can be loaded over the web interface.

Updates should only be made over http and not over https for reasons of stability.

Remote updates should be avoided as far as possible since it can happen that the **alpha UMTS WTM PC / alpha UMTS WTM 2 PC** is not accessible anymore or that the configuration changes in case of an error.

Basically, you should always load the **alpha UMTS WTM PC / alpha UMTS WTM 2 PC** firmware first and afterwards the firmware of the UMTS radio module. In case of a failure of the second update, this should be repeated after a reboot.

The bootloader is integrated into the firmware. It is not installed automatically since a failure makes the **alpha UMTS WTM PC / alpha UMTS WTM 2 PC** unusable (the modem can only be repaired by the manufacturer FMN communications GmbH) and because it is not absolutely necessary. It can be installed manually, but it does not lead to success in any case.

After a successful update of the bootloader, a reboot (interruption of the power supply) is necessary.

Troubleshooting

Error pattern	A possible cause	Measures
The power LED is not glowing.	The modem has no power supply.	1. Check the correct cabling between UMTS modem and power supply unit from the 230 V mains voltage [optional 110 V]
		2. Exchange the unit.
WWAN - continuous light with short interruptions	No SIM card inserted. PIN not correct.	1. Enter the SIM card.
		2. Check the PIN.
		3. Check the WAN settings.
LAN LED is not glowing	LAN connection cable is defective or not inserted correctly.	Check the LAN connection cable between UMTS modem and PC / network device (crossover / Patch cable)
Password was entered correctly but is displayed as being wrong.		Deactivate the cache in the browser.
Certain pages of the web interface (especially WAN and status) are not shown.		1. Reboot the unit
		2. Update the UMTS radio module firmware

Conformity

Herewith, the FMN communications GmbH declares that the **alpha UMTS WTM PC / alpha UMTS WTM 2 PC** complies with the essential requirements and the other relevant provisions of the directive 1999/5/EG (R&TTE directive).

The **alpha UMTS WTM PC / alpha UMTS WTM 2 PC** complies with the Radio and Telecommunications Terminal Equipment Act (FTEG). The conformity with the above mentioned directive is confirmed by the CE symbol on the unit.

The complete declaration of conformity can be found in the Internet under <http://www.fmncom.com>.

Maintenance

No maintenance is necessary at the **alpha UMTS WTM PC / alpha UMTS WTM 2 PC**.
The UMTS modem may only be repaired by the manufacturer or by authorized specialists.

Technical data of the UMTS modem

- Dimensions (W x D x H): approx. (95.89 x 90.17 x 24) mm
- Operating voltage: 3.3 V DC from PC/104-Bus
- Maximum power consumption: 6 W
- Average power consumption: 5 W
- Operating temperature: -25 °C ... +70 °C
- UMTS transmission rate:
 - alpha UMTS WTM PC:** HSDPA max. 1.8 MBit/s (Downstream)
UMTS max. 384 kBit/s (Downstream)
384 kBit/s (Upstream)
 - alpha UMTS WTM 2 PC:** HSDPA max. 3.6 MBit/s (Downstream)
UMTS max. 384 kBit/s (Downstream)
384 kBit/s (Upstream)
- Compliant to CE

Connections and interfaces

- Network connection over RJ45 socket (standard Ethernet, 10/100 Base-T)
- PC/104-*Plus* specification version 2.0/11-2003
- Connection of UMTS and GPS antenna over U.FL connector

Information regarding Open Source Software

This unit contains Open Source Software that may be subject to different terms of a license (e. g. GPL). The exact terms of a license are enclosed or may be seen over the user interface of the respective unit.

On demand, FMN provides the respective source codes on a medium. The medium is provided against payment of a fee of EUR 18.00 plus shipping charges. You can ask for the source codes by giving the product name and the device number at

FMN communications GmbH
Sales Department
P. O. Box 100465
99724 Nordhausen
Germany

The method of payment is payment in advance or cash on delivery.

Copyright

All rights reserved. Duplication of these instructions for use or parts thereof by any reproduction method whatsoever is not permitted without prior permission of the manufacturer.

Amendments may be published without prior notification.

Notwithstanding the above declaration, the manufacturer accepts no liability for errors in these instructions or their consequences.

For the protection of the environment!

Printed on paper bleached without chlorine, with a maximum waste paper content of 50 %.



FMN communications GmbH

Grimmelallee 4	99734 Nordhausen - Germany
P. O. Box 10 04 65	99724 Nordhausen - Germany
Phone	+49 (36 31) 56-50 00
Fax	+49 (36 31) 56-32 24
Email	info@fmn.de
Internet	www.fmncom.com

HOTLINE

+49 (36 31) 56-34 16

If you have any questions, please do not hesitate to contact us.

Subject to change.

alpha UMTS WTM PC / alpha UMTS WTM 2 PC 0113.3.0052.01

Edition: 06/07 (1111-5533)